

Progressive Safe System: Technical Specifications

Blind Spot Information Systems (BSIS)

PZ151 Compliancy Document



Requirements for fitting the Progressive Safe System: Blind Spot Information Systems and Camera Monitor Systems (CMS)

Rationale

This specification is aimed at aftermarket systems intended to enable the legacy fleet to obtain an HGV Safety Permit. Vehicles already approved to UNECE Regulation 151 are considered to have a BSIS likely to be more effective than one designed for this specification, and are therefore treated as compliant with this BSIS requirement.

Vehicles which have lower levels of direct vision carry a greater risk of allowing Vulnerable Road Users (VRU) to be hidden from view by blind spots in the critical moments before a collision. Lower direct vision vehicles force the driver to rely upon the use of six mirrors, which has a time implication in terms of reviewing multiple mirrors, and a quality implication in terms of the smaller distorted image of a VRU when compared to direct vision. This reduces the capability to use peripheral vision to identify VRUs which is afforded by high direct vision. The detection and driver warning elements of the Safe System required vehicles with low direct vision to have systems that inform the driver of the presence of VRUs in close proximity to the vehicle and actively draw their attention to it. This aims to replace the information that was not received in the form of direct vision. The Progressive Safe System is intended to build on the Safe System and to reflect a higher level of safety ambition in the same manner as improved requirements for direct vision with the new three-star threshold.

The technologies in the Progressive Safe System are not direct replacements for greater direct vision so cannot and should not be considered as direct substitutes. A digital information or warning system is not as effective at allowing an alert driver to see and correctly identify a VRU as being able to see them with the naked eye. However, part of the benefit of a turn assist system is that it can detect VRUs at the side of the vehicle some distance to the rear of the cab where direct vision is impossible. A turn assist system may also be more effective than direct vision alone at drawing the attention of an inattentive driver. These benefits would be applicable even in vehicles with five-star direct vision.

For a swift transition to Progressive Safe System technologies, the requirements set out in the following sections have been tailored to both the UK and non-UK specific environment in which they are designed to operate, and the performance of systems currently on the market. These parameters make alignment with existing regulation challenging, in some cases requiring tough performance such as removing the 900mm dead zone directly adjacent to the side of the vehicle in Regulation 151, thereby requiring detection up to the side of the vehicle. This performance-based target goes beyond UN Regulation 151 but is designed to reflect the types of

collisions seen in practice in the UK and the technology identified and assessed during the development of this specification.

High-intensity warnings, such as loud audible or other attention-taking warning signals during a driving situation are only justified if the probability for an imminent collision is high. If high intensity warnings are frequently used in situations where the driver is aware of the hazards and/or there is no urgent need for them to act, then it can lead to annoyance, potential cognitive overload, and a lack of trust in the system, and can result in alerts being ignored or switched off.

Safe Drive Systems Notes: *This gets into the core of the new regulations. Older sensor systems were often ignored or tampered with due to false alarms. The PZ151 is designed to only give out a high-intensity warnings when a VRU is picked up in the zone and:*

1. *The left indicator is engaged signaling that a maneuver will occur.*

2. *A Turn to the left is initiated by the vehicle.*

A low intensity information signal (e.g., an amber warning light) can be activated earlier and more frequently without annoying the driver, while still providing useful information to them.

Safe Drive Systems Notes: *Low intensity information signals on the PZ151 are visual in nature. This means if a VRU is detected in the nearside area of the vehicle but the probability for an imminent collision isn't high then the driver is made aware of the VRU's presence without annoying the driver.*

For a turn assist system it is appropriate to place the information signal towards the nearside of the vehicle. In addition to alerting the driver, the information should provide some indication of the location of the hazard.

Safe Drive Systems Notes: *When activated the system sends an output to trigger the side camera allowing drivers to pinpoint the location of the VRU.*

The existing Safe System recommended that systems should only provide the information signal to the driver in response to the presence of a VRU and not a car or a piece of roadside furniture (unless a collision with those items was imminent). It was not made compulsory at the time because few systems were available that could achieve it. This is no longer the case.

Safe Drive Systems Notes: *The PZ151 will not alert due to street furniture or parked cars.*

Definitions

"Blind Spot Information System (BSIS)" means a system to inform the driver of the presence of, or a possible collision with a Vulnerable Road User (VRU) at the near side of the equipped vehicle.

"Reaction time" means the time from when the information signal is given to that when a driver has reacted to that information.

"Nearside" means the side of the vehicle nearest to the pavement/road edge on a typical bi-directional road with one lane in each direction. In the UK, the near side of the vehicle is the left side.

"Information signal" means a signal intended to inform the vehicle driver about the presence of a nearby VRU close to the vehicle but not necessarily on a collision course.

"Bicycle" means a combination of a bicycle and rider.

"HMI" means the Human Machine Interface and relates to how the system interacts with the driver in terms of controls, settings, information and warnings.

"Vehicle Master Control Switch" means the device by which the vehicle's onboard electronics system is brought, from being switched off, as in the case where a vehicle is parked without the driver being present, to normal operation mode.

"Vulnerable Road User (VRU)" means an adult or child cyclist, pedestrian, e-scooter rider, horse rider or motorcyclist.

"Warning signal" means a signal emitted by the BSIS with the purpose of warning the vehicle driver when the BSIS has detected an imminent collision between the moving vehicle and a VRU in close proximity to the nearside of the vehicle.

"Information or warning signal mode" means the method by which the information or warning signal can be communicated to the driver. These can be:

- Visual – meaning a signal that is presented visually only, such as a lamp or symbol
- Audible (Tonal) – meaning a signal that uses one or more continuous or intermittent tonal sounds, such as a buzzer, horn, or beeping signal.
- Audible (Speech) – means a signal conveyed by the spoken word
- Haptic – means a signal that is conveyed by the means of the drivers sense of touch and feel, such as a vibrating seat, steering wheel or pedal.
- Multimodal – means an information signal comprising more than one of the above modes.

"Lateral separation" means the distance between the nearside of the vehicle and the VRU, measured when the vehicle and VRU are parallel to each other before any vehicle turn is commenced. The distance is measured between the plane parallel to the median longitudinal plane of the vehicle and touching its lateral outer edge, disregarding the projection of devices for indirect vision, and the median longitudinal plane of the VRU minus half of the VRU width.

Requirements

Vehicles that are approved to UNECE Regulation 151 will be deemed to comply with all of these requirements.

All other vehicles shall be fitted with a Blind Spot Information System that meets the performance requirements set out below. This will be required for the benefit of cyclists but is strongly recommended for pedestrians and other VRUs where possible.

Functional requirements

The Blind Spot Information System shall **inform** the driver about nearby VRUs that might be endangered if the vehicle were to turn so that the driver can choose not to make any turn until it is safe to do so.

Safe Drive Systems Notes: In 'Low Speed Mode' the system will show a visual warning in certain situations shown below.

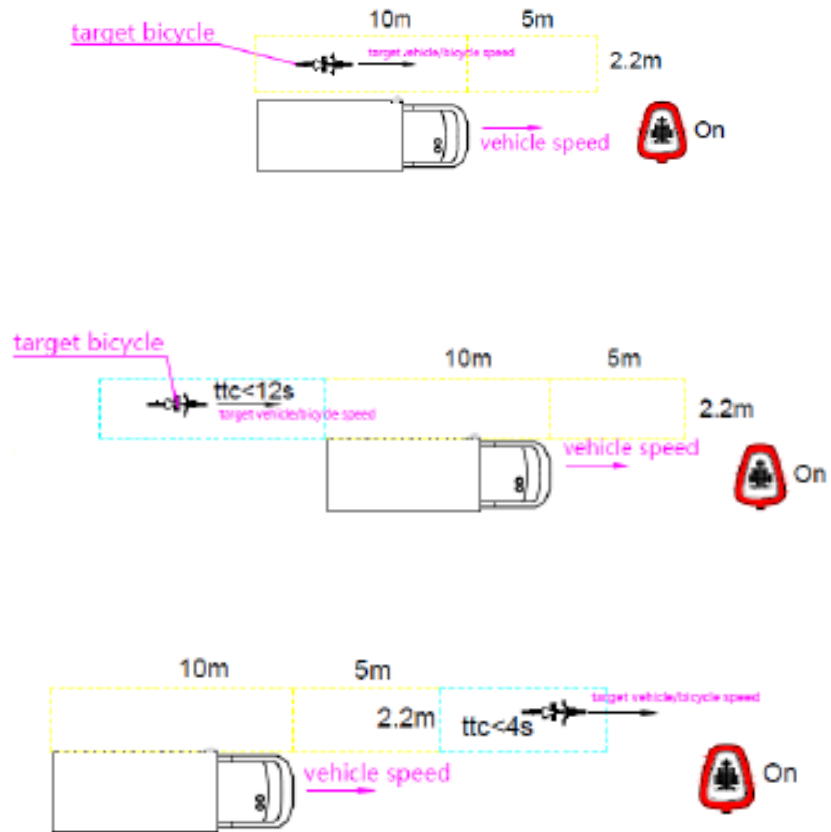

It shall also **inform** the driver about approaching VRUs while the vehicle is stationary before the VRU reaches the vehicle front, considering a driver reaction time of 1.4 seconds.

Safe Drive Systems Notes: In 'Static Mode' the system will show a visual warning in certain situations shown below. We give the driver 4 seconds reaction time as default. Although this can be changed in calibration.

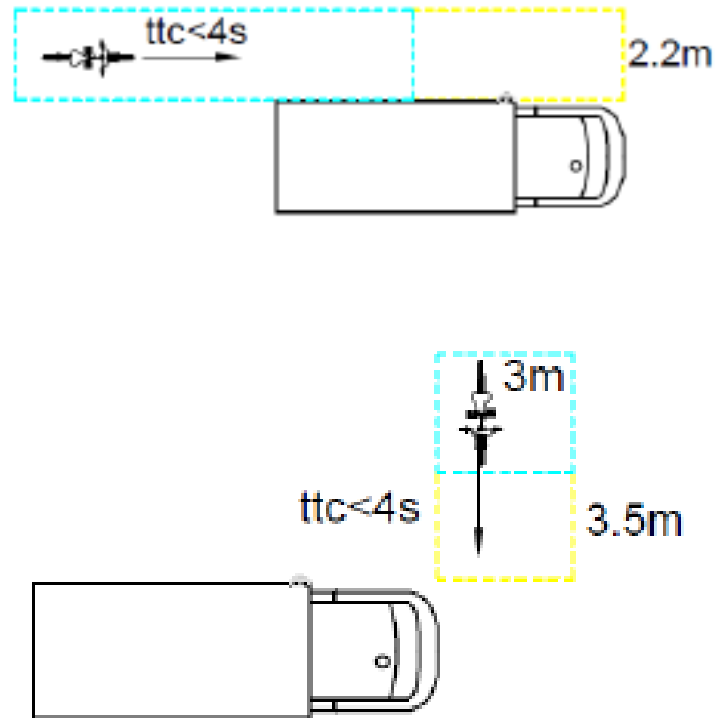

When the Blind Spot Information System identifies that a collision is imminent, for example if the vehicle turns toward the VRU,

Safe Drive Systems Notes: The PZ151 incorporates a gyro to detect turning of vehicle. It also uses the left indicator to warn as a potential turn may occur.

then it shall **warn** the driver, by means of a different and more urgent warning signal.

Safe Drive Systems Notes:

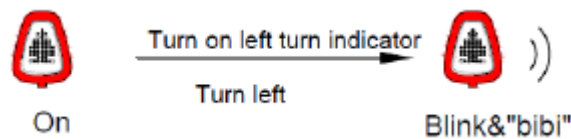

When a vehicle and a VRU are travelling in the same direction on a parallel path to each other, they can continue to do so for an infinite time without collision even if they are in close proximity. This situation does not constitute an imminent collision.

Safe Drive Systems Notes: Our system uses visual warnings only in this situation.

The information signal shall not deactivate as a result of the vehicle turning away from the VRU trajectory as long as a collision between vehicle and VRU is still possible, in the event that the driver steered back towards the VRU trajectory (i.e., where a vehicle first swings out to the right to make room for a subsequent turn to the left).

Safe Drive Systems Notes: As long as the VRU is within the zone the warning signal will not deactivate.

The system shall be “active” and able to issue information signals and warnings irrespective of the activation status of the direction indicators.

Safe Drive Systems Notes: Whilst the PZ151 can activate its high-intensity warning if the left indicator is engaged, the system is active and will warn based on movement and TTC.

The system shall be activated (or reactivated in the case of failure) upon each activation of the vehicle master control switch. The default status shall be switched on with every key cycle with the system remaining active when the ignition is switched on.

Safe Drive Systems Notes: The system meets this criteria.

Information signals shall only be given for moving objects whose speeds, trajectory, or other identifiable characteristics (such as size, shape, movement, or combination thereof) indicate that they are a VRU.

Safe Drive Systems Notes: The PZ151 uses speed and trajectory to determine VRUs in static and low speed modes.

The number of false-positive activations due to the detection of static non-VRU objects in near proximity such as cones, traffic signs, hedges and parked cars shall be minimized (see section covering assessment conditions for false positive tests). However, a warning signal is permitted if an imminent collision with a static object has been detected.

Safe Drive Systems Notes: *The PZ151 will ignore stationary objects/ parked cars and street furniture.*

Performance requirements

The BSIS shall be active at all vehicle speeds between 0 km/h and 30 km/h for all ambient lighting conditions above 15 lux. It shall detect VRUs including bicycles of all typical sizes and designs at all bicycle speeds between 5 km/h and 20 km/h.

Safe Drive Systems Notes: *Static and low speed modes are from 0-30 km/h. Our radar system works in all lighting conditions. It will pickup VRU's between 2km/h and 20km/h.*

The BSIS shall provide information signals whenever it is active and a VRU is detected within the range shown in the diagram below: from the nearside vehicle edge (taken at the widest point, excluding mirrors, auxiliary equipment and super structures above the height of 2m from the ground plane), to 2.2m lateral distance from the vehicle, ranging from the front left corner of the vehicle to at least 9m rear of this point, according to the diagram:

Safe Drive Systems Notes: *As default the system uses the below measurements but they can be increased if required.*

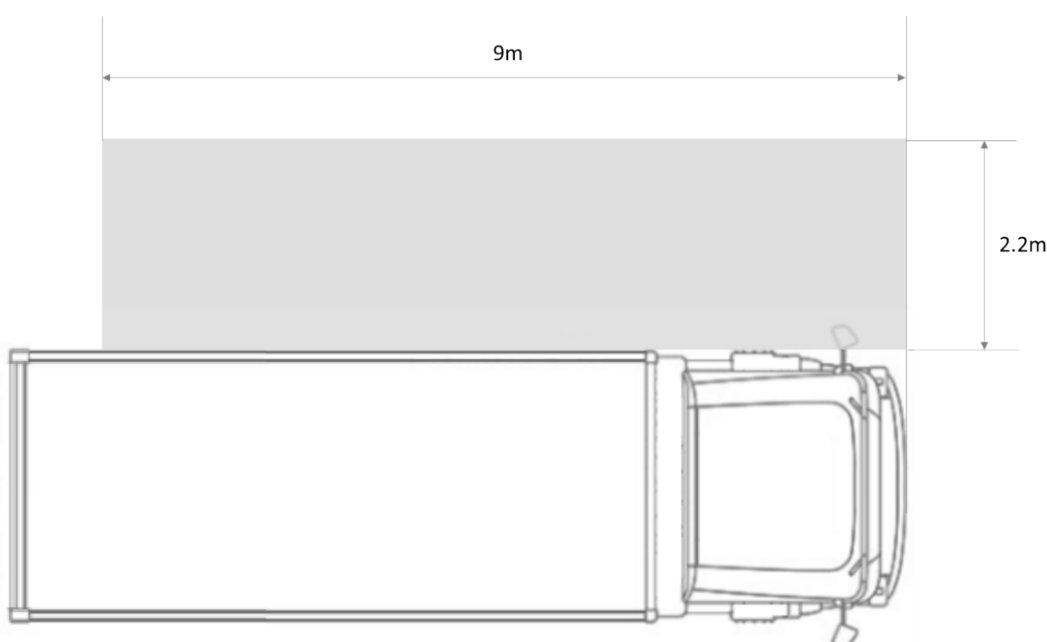

The system shall also be capable of providing collision warnings whenever it is active and a VRU is detected, and the system calculates that a collision is imminent based on the trajectories of the vehicle and/or the VRU.

Safe Drive Systems Notes: The PZ151 uses movement of the vehicle and VRUs to detect if a collision is imminent and if so provide a warning.

Human Machine Interface Requirements

The blind spot information signal shall be a visual signal that is clearly noticeable and easily verifiable by the driver from the driver's seat. This information signal shall be visible in daylight, including in direct sunlight, and at night without causing disabling glare or distraction to the driver.

Safe Drive Systems Notes: The display is an Led that will light up if a VRU is detected. This is not affected by glare or light conditions.

The device displaying the optical information signal shall be located at the near side of the vehicle at a horizontal angle greater than 30° relative to an axis parallel to the longitudinal median plane of the vehicle and going through the ocular reference point. If the driver's seating position is located on the near side of the vehicle, this value may be reduced.

If there is an increased risk of collision, for example the vehicle commences turning towards a VRU that was previously travelling parallel to the vehicle path, a warning signal shall be issued. The warning shall be a multi-modal signal comprising at least two of the following modes simultaneously: visual signal, audible (tonal) signal, or haptic signal. Where any element of the warning signal uses the same mode as the information signal, then the warning must be substantially different in presentation to the information signal. For example, if both information and warning signals use a visual signal, then the visual signal must look substantially different in respect of colour, continuous or flashing behaviour etc. when used for information or for warning.

Safe Drive Systems Notes: The display shall beep and flash if a collision is likely to occur.

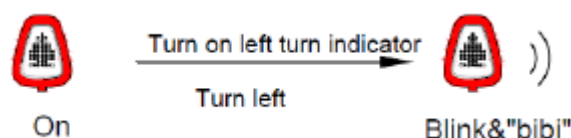





It shall, at all times, be clear to drivers of vehicles if the blind spot information system is not working correctly, such as by means of an ‘error’ or ‘fault’ visual signal.

Safe Drive Systems Notes: The PZ151 will self-diagnose faults.

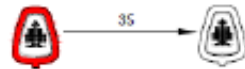
The system shall display a permanent error in the event of restricted functionality, a malfunction, (e.g., sensor failure or covering), defective information or warning signalling, partial or complete failure of the system.

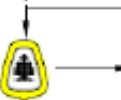
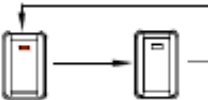
Safe Drive Systems Notes: The PZ151 will self-diagnose faults and keep the fault displayed until rectified.

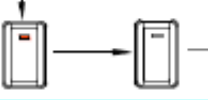
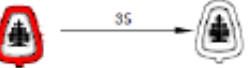
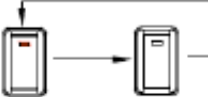
No.	System Status	Warning Method	Switch indicator
1	Sensor and GPS module self diagnosis Pass	The warning indicator will be on in red color for 3s and then go off. 	Switch indicator on. 
2	The radar was covered by objects (1)	The warning indicator will blink at a frequency of 2Hz in yellow color continuously. 	The switch indicator will blink at a frequency of 1Hz continuously. 
3	Sensor self diagnosis Fail	The warning indicator will be on in yellow color continuously. 	The switch indicator will blink at a frequency of 1Hz continuously. 
4	GPS module diagnosis Fail (2)	The warning indicator will be on in red color for 3s and then go off. 	The switch indicator will blink at a frequency of 2Hz continuously. 

Installation requirements

The system shall be installed in such a way that it is not possible for the driver to switch off the system, for example, no main electrical (on/off) switch should be available to the driver.

The system shall not adversely affect any safety critical aspect of the function or performance of the base vehicle to which it is installed.

Sensors or other means of detection, where the alignment or stability is critical to successful operation in the defined zone, shall be mounted on structures that are essentially rigid and are not liable to movement or vibration in service. Mirror arms that are adjustable in position shall not be considered suitable.

No sensors, other means of detection, or other components of the system shall be mounted such that they protrude in a manner that is liable to cause injury risk to a VRU in the event of a collision, or conflict with the type-approval requirements for sideguards, spray suppression or external projections.

Recommendations

It is recommended that:

- Systems comply with as many of the requirements of UN Regulation 151 as possible.
- When fitted to longer rigids or articulated vehicles, systems with a longer rearward detection zone are used, such that information can be provided in time to avoid collisions with a pedal cyclist at a point just ahead of the rearmost group of tractor unit axles, at least when the speed of the pedal cyclist is no more than 10 km/h in excess of the speed of the HGV (up to a maximum cyclist speed of 20 km/h).

Test procedure

The manufacturer shall provide details of the basic design of the system and, if applicable, how it is linked to other vehicle systems. The function of the system including its sensing and warning strategy shall be explained and an operator's manual/handbook shall describe how the operational status of the system is checked, whether there is an influence on other vehicle systems, and the method(s) used in establishing the situations which will result in a failure warning signal being displayed. The documentation package shall give sufficient information for the test service to identify the type of system and to aid the decision-making on the selection of worst-case conditions.

Safe Drive Systems Notes: SDS provide an operational manual. Our system has passed all TFL tests as laid out below.

Assessment conditions (true positive tests)

The tests shall take place on a flat asphalt or concrete surface.

The vehicle sensors of the blind spot information system shall not be impeded in their functionality by contaminants (e.g., ice/snow) or other means.

Visibility conditions shall allow safe travel at the required travel speeds.

The tests may be carried out in any load condition so long as the axle loads do not exceed the limit specified by the vehicle manufacturer. The manufacturer shall confirm that the function is available in all permissible load states.

The vehicle tyre pressure shall be set according to the specifications of the vehicle manufacturer.

Static test

The vehicle presented for testing shall be set up on a sufficiently large test area ready to be driven off.

The vehicle under test shall be secured against starting and rolling with the parking brake system or additional mechanical means (wheel chocks etc).

A VRU shall pass through the area covered by the Blind Spot Information System as defined in the performance requirements section above, in such a way that the movement is parallel to the longitudinal axis of the vehicle at speeds and lateral separations described in the following table overleaf:

Required

Test number	Lateral distance from nearside vehicle edge (mm)	VRU type	VRU speed (km/h)
1	500 ± 200	Cycle	7 ± 2km/h
2	1100 ± 200	Cycle	12 ± 2km/h
3	2200 ± 200	Cycle	18 ± 2km/h

Recommended

Test number	Lateral distance from nearside vehicle edge (mm)	VRU type	VRU speed (km/h)
4	300 ± 200	Pedestrian	4 ± 2km/h
5	1100 ± 200	Pedestrian	4 ± 2km/h
6	2200 ± 200	Pedestrian	± 2km/h

Compliance with the distance and speed specifications shall be demonstrated using calibrated and traceable measuring equipment, markings on the test area and film documentation. This can be done, for example, by determining speed using a GPS-based measurement system and by observing the VRU path along defined markings.

The test is passed if the presence of the VRU is signalled by the BSIS in all test cases for at least as long as part of the VRU is within the coverage area according to the performance requirements section .

Signalling of the presence of the VRU shall be confirmed with cameras that can determine the delivery of the signal and the respective position of the VRU alongside the vehicle.

This can be done, for example, by using synchronized video capture covering both the internal VRU signal and the external position of the VRU on the test markings.

Assessment conditions (false positive tests)

The vehicle presented for testing must drive at a speed of 10 ± 2 km/h on a sufficiently large test area through the centre of a marked corridor (width: vehicle width + 2 ± 0.1 m, length: 20 ± 0.1 m, distance between markings: maximum 5 ± 0.1 m, marking height: maximum 5 cm).

A sign in accordance with BS EN 12899 1:2007(a) Fixed vertical road signs – fixed signs) shall be attached at a usual height in line with the left-hand row of markings (test setup see figure below). No other objects or VRUs should be in the covered area. Care must be taken to ensure that the right row of markings and the traffic sign are within the coverage area during the test.

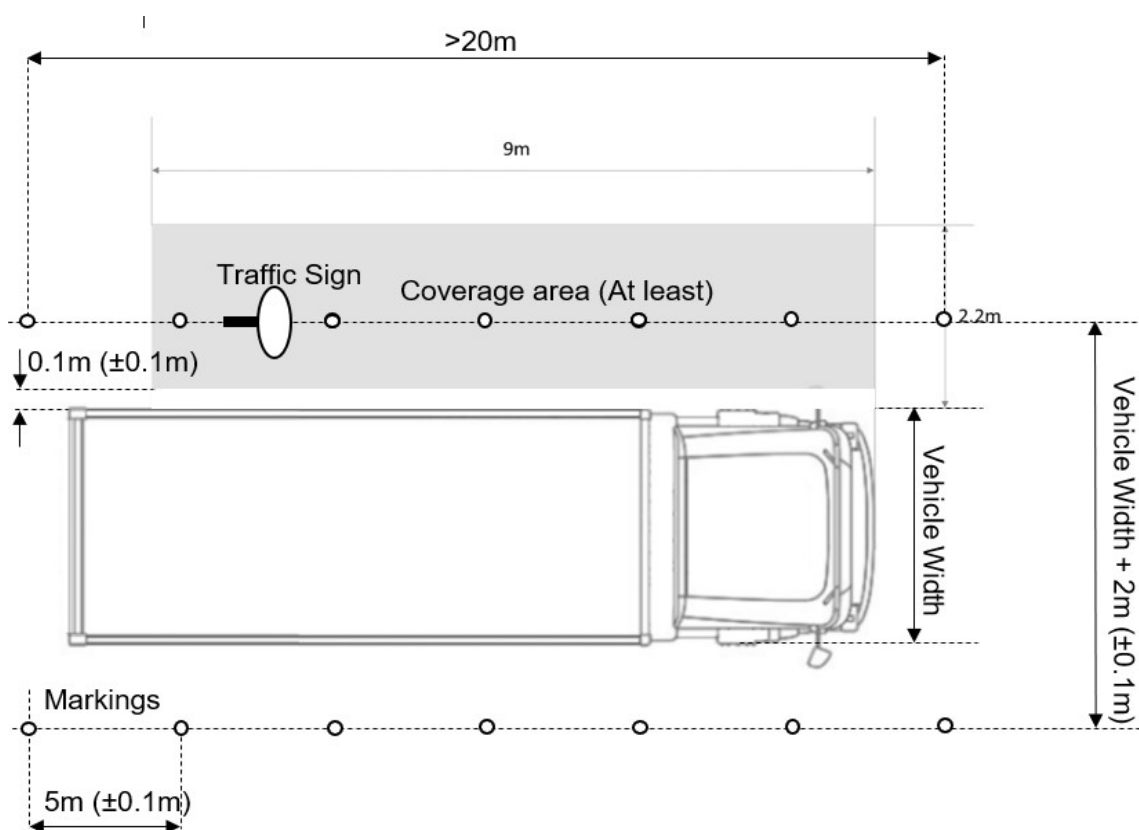

The test is passed if no information or warning signal is issued.

