

# Progressive Safe System: Technical Specifications

Moving Off Information Systems (MOIS)

## PZ159 Compliancy Document



# **Requirements for fitting the Progressive Safe System: Moving Off Information Systems (MOIS)**

## **Rationale**

This specification is aimed at aftermarket systems intended to enable the legacy fleet to obtain an HGV Safety Permit. Vehicles already approved to UNECE Regulation 159 are considered to have a Moving off Information Systems (MOIS) likely to be more effective than one designed for this specification and are therefore treated as compliant with this MOIS requirement.

Vehicles which have lower levels of direct vision risk allowing Vulnerable Road Users (VRUs) to be hidden from view by blind spots in the critical moments before a collision than one with higher direct vision. Lower direct vision vehicles force the driver to rely upon the use of six mirrors, which has a time implication in terms of reviewing multiple mirrors, and a quality implication in terms of the smaller distorted image of a VRU when compared to direct vision. This reduces the capability to use peripheral vision to identify VRUs which is afforded by high direct vision vehicles. The detection and driver warning elements of the Safe System required vehicles with Low direct vision to have systems that inform the driver of the presence of VRUs in close proximity to the vehicle and actively draw their attention to it. This aims to replace the information lost in the form of direct vision. The Progressive Safe System is intended to build on the Safe System and to reflect a higher level of safety ambition in the same manner as improved requirements for direct vision with the new 3-Star threshold.

The technologies in the Progressive Safe System are not direct replacements for direct vision improvements so cannot and should not be considered as direct substitutes. It can be considered that an information or warning system is not as effective at allowing an alert driver to see and correctly identify a VRU as using direct vision. However, part of the benefit of a Moving Off Information System is that it can detect vulnerable road users in front of vehicles where direct vision is impossible for larger vehicles, and another benefit is that it may be more effective at drawing the attention of a driver that is inattentive (e.g., distracted).

Most incidents while moving off result in a collision with the front of the vehicle somewhere between the centre of the vehicle and the nearside edge of the vehicle, although to some degree collisions can and do occur across the entire vehicle width. The Safe System did not require sensors to be fitted covering the front blind spot of a vehicle. This was only a recommendation. It also did not specify any field of view in this area that should be covered by a sensor system, although camera monitoring systems could be deployed in this area. Through Fleet Operator Recognition Scheme (FORS) gold accreditation it was possible to expect that some vehicles were fitted with frontal sensors.

High-intensity **warnings** during a driving situation are only justified if the probability of an imminent collision is high – otherwise vehicle drivers tend to ignore the system alerts and can be irritated or even distracted by them.

**Safe Drive Systems Notes:** *The PZ159 uses visual only warnings on the display when the vehicle is stationary and a VRU is in the zone. If the vehicle moves off and  $TTC < 1.4s$  (Default) then a high intensity beep and flash is initiated.*

A low intensity **information** signal can be activated sufficiently early to avoid annoying the driver while still providing useful information.

In addition to alerting the driver, the information should indicate the location of the hazard.

**Safe Drive Systems Notes:** *The visual display will indicate if the VRU is to the right/left or center of the vehicle and also the distance away.*

It is assumed to be possible to design a human- machine-interface for Moving Off Information Systems in a way that does not overload drivers when the information is not needed, for instance by requiring the use of a less intrusive form of signal.

Therefore, this requirement requires the activation of an **information** signal to be issued whenever pedestrians or cyclists are within or about to enter the critical blind spot area in front of the vehicle.

If a collision risk with a VRU in the detection zone becomes imminent, e.g. when the vehicle moves off from rest or prepares to move away (for instance; selecting a forward gear, releasing the foot or parking brake or depression of the throttle pedal), then a higher intensity warning **must** be issued.

**Safe Drive Systems Notes:** *The PZ159 uses visual only warnings on the display when the vehicle is stationary and a VRU is in the zone. If the vehicle moves off and  $TTC < 1.4s$  (Default) then a high intensity beep and flash is initiated.*

In order to enable a swift transition to Progressive Safe System technologies, the requirements set out in the following sections have been tailored to both the UK and non-UK specific environment in which they are designed to operate and the performance of systems currently on the market. This specification defines performance requirements based on subject vehicles that are stationary or moving-off from rest in a straight line for speeds of 5 km/h or less. Collision analysis data shows that the provision of information and warnings during these vehicle manoeuvres is appropriate since the signals needs to be present sufficiently early to alert the driver of VRUs in close proximity to the front of vehicles.

## Definitions

"Moving Off Information System (MOIS)" means a system to detect and inform the driver of the presence of pedestrians and cyclists in the close-proximity forward blind-spot of the vehicle and, if deemed necessary based on manufacturer strategy, warn the driver of a potential collision

"Vulnerable Road User (VRU)" means an adult or child pedestrian or an adult or child cyclist.

"Information signal" means a signal emitted by the MOIS with the purpose of informing the vehicle driver about a VRU in close proximity to the front of the vehicle

"Warning signal" means a signal emitted by the MOIS with the purpose of warning the vehicle driver when the MOIS has detected an imminent frontal collision with a VRU in close proximity to the front of the vehicle.

"Vehicle master control switch" means the device by which the vehicle's onboard electronics system is brought, from being switched off, as in the case where a vehicle is parked without the driver being present, to a normal operation mode.

"Vehicle front" means the plane perpendicular to the median longitudinal plane of the vehicle and touching its foremost point, disregarding the projection of devices for indirect vision and any part of the vehicle greater than 2.0 m above the ground.

"Nearside" means the left side of the vehicle for left-hand traffic.

"Vehicle width" means the distance between the nearside and offside vehicle planes.

"Vehicle plane" means the planes parallel to the median longitudinal plane of the vehicle and touching its most outboard point in the nearside or offside direction, disregarding the projection of devices for indirect vision and any part of the subject vehicle higher than 2.0 m above the ground.

"Nearside separation plane" means the plane parallel to the longitudinal plane of the vehicle and located 0.5 m outboard from the nearside vehicle plane.

"Offside separation plane" means the plane parallel to the longitudinal plane of the vehicle and located 0.5 m outboard from the offside vehicle plane.

"At rest" means a situation where the vehicle is stationary and is not in a condition where imminent movement is likely.

"Potential moving off manoeuvre" means the subject vehicle being stationary, the vehicle master control switch activated, the vehicle in a normal operation mode.

"Low speed manoeuvre" means the subject vehicle being in a normal operation mode, moving forward in a straight line at speeds of below 5 km/h.

"Critical blind spot area" means the area defined by the maximum extent of the nearside and offside separation planes measured laterally and the maximum extent of coverage ahead of the vehicle front measured longitudinally.

## Requirements

Vehicles that are approved to UNECE Regulation 159 will be deemed to comply with all of these requirements.

All other vehicles shall be fitted with a MOIS that meets the requirements contained in the Requirements section of this specification.

## Functional requirements

### When stationary

The MOIS shall **inform** the driver of the presence of VRUs who are within or about to enter the critical blind spot area ( $d_w$  in figure below) in front of a stationary vehicle and that might be endangered if the vehicle were to move off, by means of a visual signal.

**Safe Drive Systems Notes:** The display will show distance and location to the left or right if a VRU is entering the zone as below.



The MOIS shall **warn** the driver of the risk of an imminent collision with VRUs who are within or about to enter the critical blind spot area ( $d_w$  in figure below) in front of the vehicle, if the vehicle is in a potential moving off manoeuvre.

**Safe Drive Systems Notes:** The system uses a combination of GPS and gyro to detect when the vehicle moves off from standstill or is travelling at low speeds. Based on this information the system calculates the TTC (Time to Collision) of VRU's in or entering the detection area. If the TTC is  $\leq 1.4s$ , and the probability of an imminent collision is high, then the LED Display will do a high intensity double beep to warn the driver.

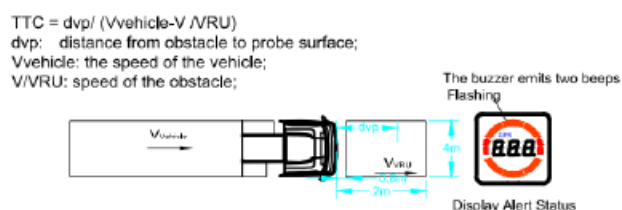

The MOIS shall not issue a collision warning if the vehicle is in the 'at rest' condition. An information signal is still required in accordance with the first paragraph of this 'when stationary' requirement.

**Safe Drive Systems Notes:** *The PZ159 features a handbrake wire which mutes the system but keeps the static information signal.*

The exact parameters that determine if a vehicle has moved from an 'at rest' condition to a 'potential moving off manoeuvre' shall be determined at the discretion of the manufacturer. However, a vehicle that is stationary with either the park brake or the service brake applied shall always be considered 'at rest'. The manufacturers strategy should aim to use parameters that identify a potential moving off manoeuvre at the earliest opportunity.

**Safe Drive Systems Notes:** *The system uses movement via the gyro and GPS to change to a "potential moving off manoeuvre".*

A warning signal shall be maintained only for as long as the conditions specified in the performance requirements below are fulfilled.

### ***When performing a moving-off manoeuvre***

When a vehicle performing a moving off manoeuvre has already detected a VRU and provided an information or warning signal, the MOIS shall maintain the signal even if the vehicle comes to a standstill. The information/warning signals shall be maintained for as long as the VRU remains in the defined zone in front of the vehicle.

**Safe Drive Systems Notes:** *The system will show a warning/information signal for as long as a VRU is in the zone.*

The MOIS shall be active and able to issue information signals and warnings irrespective of whether the vehicle is stationary or in motion.

**Safe Drive Systems Notes:** *The system does this.*

The MOIS shall be activated (or reactivated in the case of failure) upon each activation of the vehicle master control switch. The default shall be on with every key cycle with the system remaining active when the ignition is switched on .

## Performance requirements

The MOIS must be able to provide information and warning signals across at least the following areas:

Lateral coverage area bounded by the nearside and offside vehicle planes (taken at the widest point, excluding mirrors, auxiliary equipment and super structures above the height of 2m from the ground plane), defined as  $d_w$ , plus nearside and offside separation planes (defined as  $d_{NSP}$  and  $d_{OSP}$  respectively) each extending 500mm laterally from vehicle side planes.

Longitudinal coverage from the vehicle front plane as set out according to the following table and figure:

| Star rating                       | Longitudinal dimensions (mm)                                    | Lateral dimension (mm)                                 |
|-----------------------------------|---|--|
|                                   | Minimum extent of coverage area ahead of front plane of vehicle | Vehicle width + nearside and offside separation planes |
| <b>Vehicles rated 0 to 2 star</b> | 2000  | $d_w + D_{NSP} + D_{OSP}$                              |

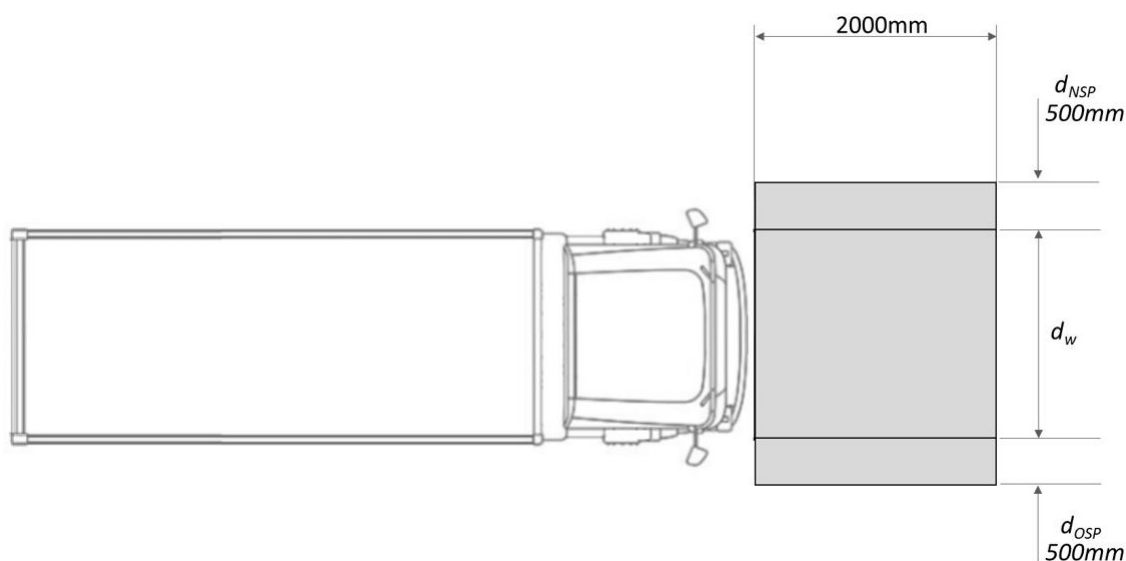

**Safe Drive Systems Notes: System can be calibrated to exact measurements needed.**

The MOIS shall provide an information signal for VRUs that are stationary or moving forward at speeds of between 3 km/h and 5 km/h when travelling from the nearside or offside of the vehicle in a direction perpendicular to the vehicle median longitudinal plane.

**Safe Drive Systems Notes:** *The system will provide an information system in the situations advised above.*

When performing a potential moving-off manoeuvre, the MOIS shall provide a warning signal to the driver indicating the imminent collision with the VRUs moving at speeds of between 3 km/h and 5 km/h, when travelling from the nearside or offside of the vehicle in a direction perpendicular to the vehicle median longitudinal plane at vehicle speeds between 0km/h and 5km/h.

**Safe Drive Systems Notes:** *The system will provide an information system in the situations advised above.*

### Human Machine Interface

Information signals should only be given for objects whose speeds, trajectory, or other identifiable characteristic (such as size, shape, movement, or combination thereof) indicate that they are a Vulnerable Road User.

**Safe Drive Systems Notes:** *The PZ159 uses speed and trajectory to determine VRUs.*

The number of false-positive information signals due to the detection of non-VRU objects, such as other vehicles, shall be minimized. However, a warning signal is permitted if an imminent collision with a non-VRU object has been detected within the detection area as defined in the performance requirements section.





**Safe Drive Systems Notes:** *The PZ159 uses speed and trajectory to determine VRUs. It will not react to stationary non VRUs when static or vehicles travelling above standard VRU speeds.*



It shall be clear to drivers of vehicles if the MOIS becomes impaired or unavailable.

Restricted functionality, a malfunction, (e.g. sensor failure or covering), defective information or warning signalling, partial or complete failure of the system shall be indicated by means of an error message. If a permanent error display is not possible, an error message can alternatively be displayed, which shall be confirmed by the driver.

**Safe Drive Systems Notes: The PZ159 will self-diagnose faults and keep the fault displayed until rectified.**

| N.O. | System Status                       | Alarm Mode   |                 |
|------|-------------------------------------|--|-----------------|
|      |                                     | Digitron   | Built-in Buzzer |
| 1    | System Self-Test Passed             |                             | Make a beep     |
| 2    | Sensor Quality Inspection Abnormal  |                            | Make Two beeps  |
| 3    | Sensor Obstructed by Foreign Object | Flashes Yellow at 2Hz<br> | NO              |
| 4    | Internal GPS anomaly in the display |  No GPS Display           | NO              |

The collision warning signal shall be provided by the means of a combination of at least two modes selected from an optical signal, acoustic signal or haptic signal. Where the collision warning signal is provided by using an optical mode, this shall be a signal differing from those specified for the information signal.

**Safe Drive Systems Notes: The information signal is a solid visual alert whereas the warning signal is a flashing visual alert with audible alert.**

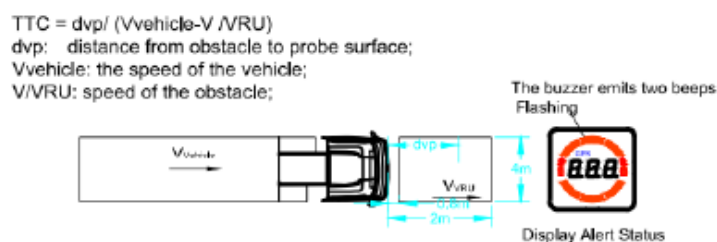

The collision warning signal shall be easily understandable for the driver to relate the signal to a potential collision.

The information and warning signal (if optical) shall be visible by daylight and at night.

**Safe Drive Systems Notes:** *The system uses an auto dimming display which uses colour/ flashing and audible alerts to easily convey meaning.*

## **Installation requirements**

The system shall be installed in such a way that it is not possible for the driver to completely switch off the system, for example, no main electrical (on/off) switch should be available to the driver.

The system shall not adversely affect any safety critical aspect of the function or performance of the base vehicle to which it is installed.

Sensors or other means of detection, where the alignment or stability is critical to successful operation in the defined zone, shall be mounted on structures that are essentially rigid and are not liable to movement or vibration in service. Mirror arms that are adjustable in position shall not be considered suitable.

No sensors, other means of detection, or other components of the system shall be mounted such that they protrude in a manner that is liable to cause injury risk to a VRU in the event of a collision, or conflict with the type approval requirements for sideguards, spray suppression or external projections.

## **Assessments**

The manufacturer shall provide a documentation package which gives access to the basic design of the system and, if applicable, how it is linked to other vehicle systems. The function of the system including how it detects and warns and VRUs shall be explained and the documentation shall describe how the operational status of the system is checked, whether there is an influence on other vehicle systems, and the method(s) used in establishing the situations which will result in a failure warning signal being displayed. The documentation package shall give sufficient information for TfL and or testing service to identify the type of and to aid the decision-making on the selection of worst-case conditions.

**SDS provide an operational manual. Our system has passed all TFL tests as laid out below.**

### **Assessment conditions (true positive tests)**

The tests shall take place on a flat asphalt or concrete surface.

The vehicle sensors of the MOIS system shall not be restricted in their functionality by contaminants (e.g., ice/snow) or other means.

Visibility conditions shall allow safe travel at the required travel speeds.

The tests may be carried out in any load condition so long as the axle loads do not exceed the limit specified by the vehicle manufacturer.

[Note] For the load condition requirement above, a confirmation from the manufacturer of the MOIS should be provided indicating that the function is available in all permissible load states.

The vehicle tyre air pressure shall be set according to the specifications of the vehicle manufacturer.

### **Information signal - Lateral crossing tests with moving VRU**

The motor vehicle presented for testing shall be set up on a sufficiently large test area ready to be driven off.

The vehicle under test shall be secured against starting and rolling with the parking brake system or additional mechanical means (wheel chocks etc).

A VRU shall pass through the area covered by the MOIS in such a way that the movement is perpendicular to the longitudinal axis of the vehicle at speeds and longitudinal separations described in the below table.

The centreline of the VRU shall be used for placement on the longitudinal distance from the vehicle front. VRU centreline is defined as the median longitudinal plane of the VRU.

| Test number | Longitudinal distance from vehicle front (mm) | VRU orientation                      | VRU type   | VRU speed (km/h) |
|-------------|---|--------------------------------------|------------|------------------|
| 1           | 500 ± 200                                     | Perpendicular to vehicle centre line | Cycle      | 3 ± 2km/h        |
| 2           | 2000 ± 200                                    | Perpendicular to vehicle centre line | Cycle      | 5 ± 2km/h        |
| 3           | 500 ± 200                                     | Perpendicular to vehicle centre line | Pedestrian | 4 ± 2km/h        |
| 4           | 1000 ± 200                                    | Perpendicular to vehicle centre line | Pedestrian | 4 ± 2km/h        |
| 5           | 2000 ± 200                                    | Perpendicular to vehicle centre line | Pedestrian | 4 ± 2km/h        |

Compliance with the distance and speed specifications shall be demonstrated using calibrated and traceable measuring equipment, markings on the test area and film documentation.

[NOTE] This can be done, for example, by determining speed using a GPS-based measurement system and by observing the VRU path along defined markings.

The test is passed if the information signal is active in all test cases at least as long as part of the VRU is within the coverage area, according to the coverage areas set out above.

Signalling of the VRU shall be confirmed with calibrated measuring equipment that can determine the delivery of the signal and the respective position of the VRU alongside the vehicle.

[NOTE] This can be done, for example, by using synchronized video capture covering both the internal VRU signal and the external position of the VRU on the test markings.

### **Warning signal - Static VRU**

The motor vehicle presented for testing shall be set up on a sufficiently large test area ready to be driven off.

The whole of a pedestrian shall be placed anywhere within the zone defined by the width  $d_w$  and within 2m from the front of the vehicle and provide a warning signal.

For systems that use triggers such as throttle depression, gear engagement or brakes release to determine an increase in collision risk the vehicle can remain secured against starting and rolling through mechanical means (wheel chocks etc). In these instances, a human target can be used.

For systems that use forward motion or other vehicle movement metrics to determine an increase in collision risk a pedestrian dummy shall be used.

The test is passed if the warning signal, as defined by the system designer, is signalled within 0.5s of the collision risk trigger being detected.

Signalling of the VRU shall be confirmed with calibrated measuring equipment that can determine the delivery of the signal and the time the signal was given.

[NOTE] This can be done, for example, by using synchronized video capture covering both the internal VRU signal and the external position of the VRU on the test markings.